

Horizontal Moulding Machine Disa Forma 3030

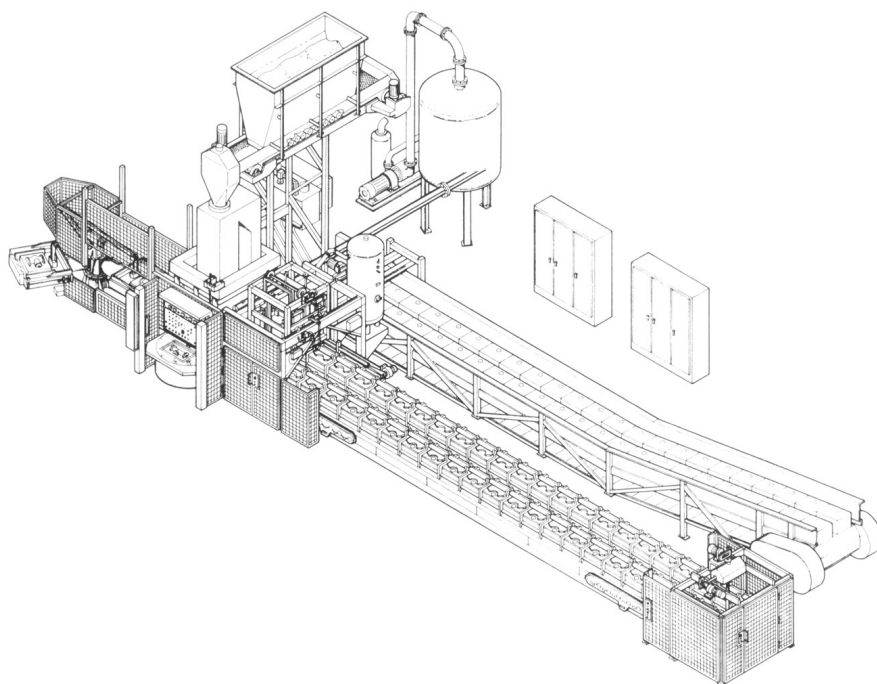

The figure shows the version of the "right equipment" we offer for sale "version of the left", ie where the pouring and cooling line is located topping the operator interface.

Dimensions produced forms (Width x length): 560 x 720 - mm

The height adjustable mold in a liquid (the upper flask bottom flask x) height of the upper and lower half of the mold can be adjusted independent from each other: 130 / 130 ÷ 250 / 250 - mm

The maximum size of switching operations: < 0,4-mm

The volume of the mold after compression: 0,1 ÷ 0,2 - m

Consumption molding at high speed, forming: 26 ÷ 45 t/h

Dimensions pattern plates:

Full 1/1: 490 x 650 x 30 -mm

Half 1/490 x 300 x 30 -mm

The quarter 1/246 x 300 x 30 -mm

adjustable ironing pressure: 30 ÷ 77 N / cm²

Maximum capacity: 50 ÷ 55 molds / hour

Average time of the core settlement: about 4 ~ 6 se

The average time of 1 form cycle: 20 ÷ 24 -sec

Maximum power consumption of the cooling water (pH 6 ÷ 8) -system hydraulic (oil cooler) - system vacuum (vacuum pump): 27 dm³ / min 116 dm³ / min

The pressure of the cooling water~ 2 to 3 at.

Compressed air consumption ~ 1.00 m³ / min

The maximum pressure in the hydraulic system during ironing: 250-bar

Installed capacity (forming the body itself and peripherals included in the machine) - pump drive motor power

The power of the heating elements in the oil tank - engine power vacuum pump - motor powers other drives~ 167 kW including 55 -kW

Control voltage: 24V

The length of the flooding: 33,71- m

The length of the cooling: 21.60 - m

Number of pallets 89 –unit

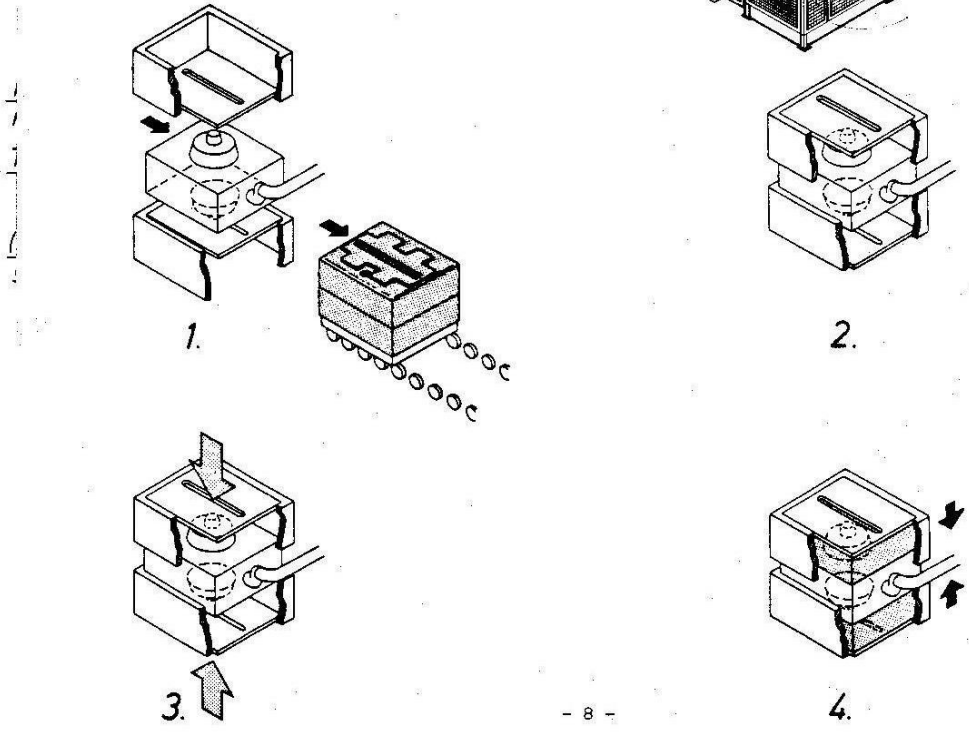
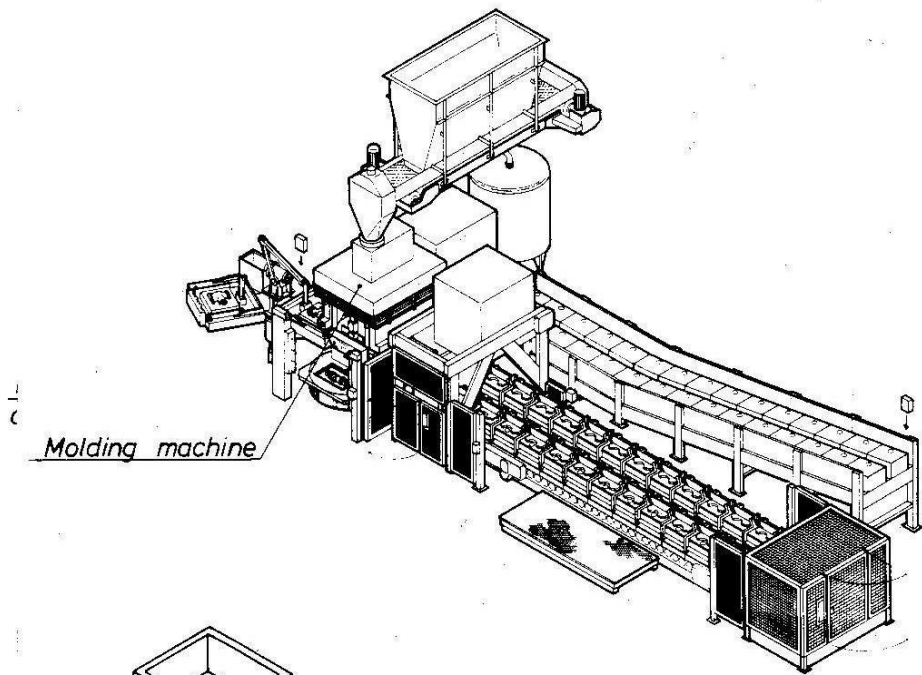

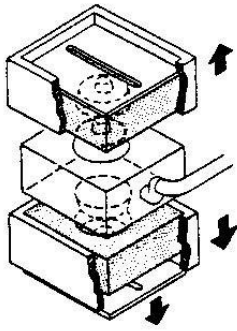

5.

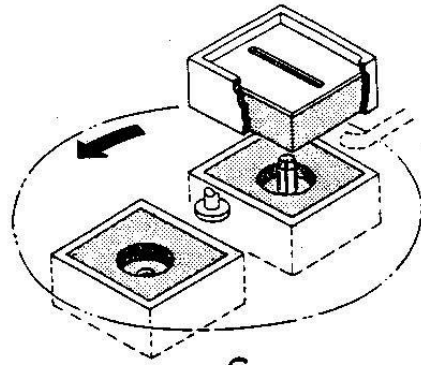

6.

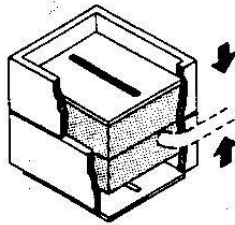

7.

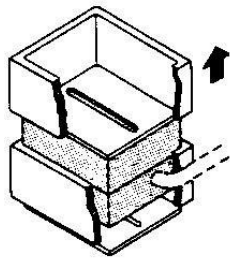

8.

